

Using Multifocal Glasses



Using Multifocal Glasses

Multifocal glasses are designed to help you see clearly at different distances using one pair of lenses. They are helpful if you need one prescription for seeing far away and a different power for reading or close-up work. At first, they may feel unusual, but with practice, most people adjust within a few days. This guide explains how to use your multifocal glasses and how to make adaptation easier.

Understanding Your Lenses

Multifocal lenses use a blended transition between 3 different powers, without any lines:

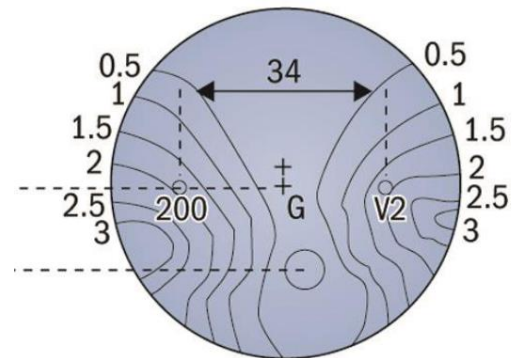
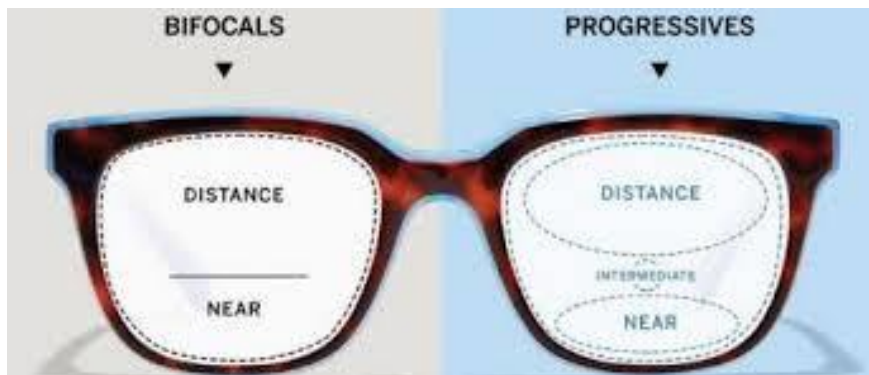

Power map of a Multifocal lens
(Left eye)

1. Distance Zone:

The top part of the lens is for seeing things that are far away, like road signs or the television.

2. Intermediate (Dashboard/ Computer) Zone:

The middle part helps with tasks at arm's length, such as looking at a computer screen.

3. Near (Reading) Zone:

The bottom part is for reading books, using your phone, or looking at anything close-up.

Using Your Multifocal Glasses

You will use different parts of the lens by moving your eyes and slightly adjusting the angle of your head.

For distance:

Look straight ahead and keep your chin level. Use the top section of the lenses. This is the correct posture for walking, driving, or watching TV.



For computer work or tasks at arm's length:

Lift or lower your chin slightly until the middle zone feels clear. You may need to adjust your chair or screen height to make this more comfortable.



For reading or close-up work:

Look down your nose through the lower part of the lenses. Try adjusting your chin position or moving the material closer or farther away until it looks sharp.



Tips for Getting Used to Them

Wear them regularly

The more you wear your multifocal glasses, the faster your eyes and brain will adapt. Try wearing them non-stop instead of switching between old glasses and the new ones.



Move your head, not just your eyes

When looking to the side, turn your head slightly so you continue to look through the central part of the lens. This helps reduce blurred vision to the side.

Be careful on stairs

When going up or down stairs, **look through the top of the lenses** by lowering your chin. This keeps the steps looking clear.



Give it time

It is normal to feel some mild distortion in your vision during the first few days. This usually improves quickly as your brain learns how to use the lenses.

Do I need to contact my Optometrist?

If you still feel uncomfortable after two to three weeks, or if you have headaches, dizziness, or trouble seeing clearly in the distance, speak to your optometrist. Your lenses may need adjustment to improve comfort and clarity.